

A22 Planfräser *Face mills, Fraises à surfacer, Frese a spianare*

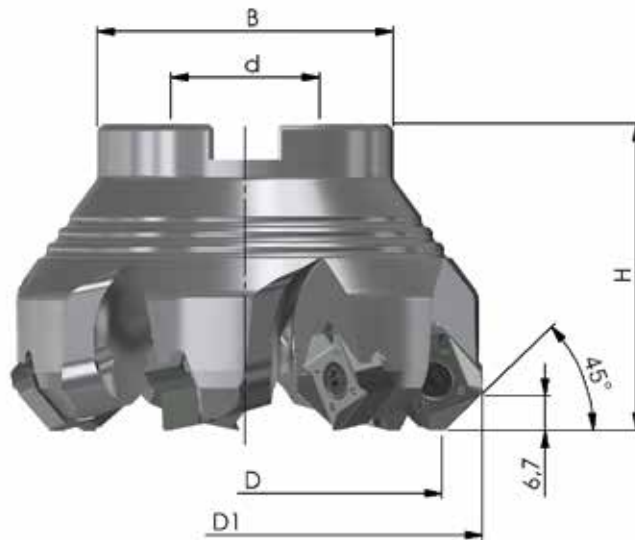











Aufsteckfräser *Shell type mills, Fraises à alésage, Frese per attacco a manicotto*



Bestell-Nr. <i>Order-No., Référence, Codice</i>	D	D ₁	H	d	B	Z	MS
45PP-050-A22-4	40	65	50	22	46	4	MS-10x25-912
45PP-063-A22-5	50	78	50	22	46	5	MS-10x25-912
45PP-080-A22-6	63	95	60	27	58	6	MS-12x35-912
45PP-100-A22-7	80	115	60	32	78	7	MS-16x35-6912
45PP-125-A22-9	100	140	63	40	90	9	MS-20x50-7991
45PP-160-A22-11	125	175	63	40	90	11	MS-20x50-7991
Enge Teilung <i>close pitch, à pas réduit, a passo stretto:</i>							
45PP-050-A22-5	50	65	50	22	46	5	MS-10x25-912
45PP-063-A22-6	63	78	50	22	46	6	MS-10x25-912
45PP-080-A22-7	80	98	60	27	58	7	MS-12x35-912
45PP-100-A22-9	100	118	60	32	78	9	MS-16x35-6912
45PP-125-A22-11	125	140	63	40	90	11	MS-20x50-7991
45PP-160-A22-13	160	175	63	40	90	13	MS-20x50-7991

A22 Fräswendepplatten und Schnittdaten

Milling inserts and parameters, Plaquettes de fraisage et paramètres, Inserti e parametri di taglio

		HC45 (code 41)	HC30 (code 52)	XC35 (code 46)	HC20 (code 53)		
	JMA22-584 IK 16,8 x 7,32 R1,0 H M  	Order-No A22A-XD41	A22A-WC52		A22A-UB53		
	f_z [mm]	0,30 (0,15-0,50)	0,25 (0,10-0,45)		0,40 (0,20-0,50)		
	JMA22-884 IK 16,8 x 7,32 R1,0 M S  	Order-No A22B-ZD41		A22B-EE46	A22B-YC53		
	f_z [mm]	0,30 (0,15-0,50)		0,25 (0,10-0,45)	0,40 (0,20-0,50)		
							
	JMA22-884B IK 16,8 x 7,32 R1,0 U  	Order-No			A22B-GF53		
	f_n [mm/U]				2,00 (1,00-3,00)		

H Wendepplatten für robuste Zerspänung

M Wendepplatten für mittlere Zerspänung

S Wendepplatten für leichte Zerspänung

U Wendepplatten für universelle Zerspänung



 Wendepplatten gesintert

 Wendepplatten geschliffen

 Verpackungseinheit

V_c [m/min]	Stahl Steel Acier Acciaio	Rostfrei Stainless Acier inoxydable Inossidabile	Guss Cast Iron Fonte Ghisa	NE-Metalle Non-ferrous metals Non ferreux Metalli non ferritici	Hochwarmfest Highly heat-resistant Superalliages Resistente al calore	Gehärtet Tempered Aciers traités Temprato
HC45	250 (200 - 350)	240 (140 - 300)	240 (130 - 280)			
HC30	160 (120 - 220)	200 (100 - 300)			60 (40 - 200)	
XC35	160 (120 - 220)	200 (100 - 300)			60 (40 - 200)	
HC20			260 (180 - 350)			80 (40 - 120)

Ersatzteile Spare parts, Pièces de rechange, Parti di ricambio

	SS 5,0-4 (M = 4,8-5,0 Nm)		T 20		Fett Grease, Graisse, Grasso
---	-------------------------------------	---	-------------	---	--

A20 Montageanleitung Breitschichtplatte *Assembly instruction wiper insert, Instruction de montage de la plaquette racleuse, Istruzioni d'impiego per il montaggio dell' inserto raschiante*

JMA22-584
JMA22-884

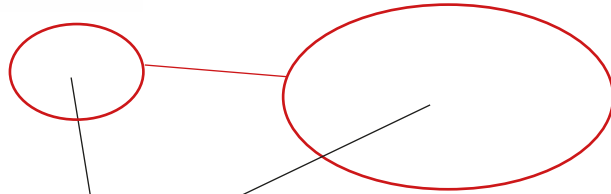

1x JMA22-884B-HC20